

APRIL 2023



UT-ID 22.17.1-1

UNITEC Otis Glide[®] A Specification and Ordering Guide

NONDISCLOSURE WARNING

This work contains proprietary information and is the property of UNITEC. It is distributed only to those employees with a need to know the information and may not be reproduced, disclosed, or distributed to any person outside the employ of UNITEC without written authorization from an officer thereof. UNITEC competitors, customers, former employees, retirees, members of the general public and consultants not bound by a written nondisclosure agreement are among those outside the employ of UNITEC. In the event that an employee in the possession of this work no longer needs the information, retires, resigns, is terminated or laid off from UNITEC, or in the event that a person outside the employ of UNITEC comes into possession of this work, such employee or person should destroy the work or return it to UNITEC.

Any unauthorized reproduction, disclosure or distribution by any person of any portion of this work may be a breach of a duty owed by such person to UNITEC and could result in damages actionable at law.

PROHIBITION ON COPYING

Any unauthorized reproduction, disclosure or distribution of copies by any person of any portion of the work may be a violation of Copyright Law of the United States of America and other countries, could result in the awarding of Statutory Damages of up to \$250,000 (17 USC 504) for infringement and may result in further civil and criminal penalties. All rights reserved.

PUBLICATION CATALOGING DATA

First Issue: March 2020
Revision April 2023

Master Index Control Number:
Part Number: UT-ID 22.17.1-1

Comments or questions about the information contained in this publication should be directed to:

UNITEC
212 West Newberry Road
Bloomfield, CT 06002
(800) 328-7840 Phone

Unpublished Work - © UNITEC, 2020

Table of Contents

1	DESCRIPTION.....	2
2	DOOR OPERATOR COMPONENTS	3
3	DOOR HAND & TYPE.....	7
3.1	DOOR TYPE.....	7
3.2	DOOR HAND	7
4	PART NUMBERS, AVAILABILITY, AND ORDERING GUIDELINES.....	8
5	ELECTRICAL INTERFACE COMPONENTS.....	11
5.1	BASIC INFORMATION	11
5.2	PART ORDERING INFORMATION	12
5.2.1	<i>Identifying Car Controller Software Compatibility.....</i>	<i>13</i>
5.2.2	<i>Identifying Traveling Cables.....</i>	<i>14</i>
5.2.3	<i>Selecting the Power Supply.....</i>	<i>14</i>
5.2.4	<i>Selecting the Electrical Interface Kit.....</i>	<i>15</i>
5.2.5	<i>Selecting the ERU</i>	<i>18</i>
APPENDIX A: PART NUMBERS.....		19

All jobsite work activities must comply with applicable Otis Safety Policies and local regulatory requirements. If you are unsure of the requirements, please stop work immediately and consult your supervisor or EH&S.

1 Description

The Otis Glide A (Figure 1) is a closed-loop linear door operator. This document provides basic ordering and specification guidance for Modernization and Open Order upgrade applications of the Glide-A door operator.

The Glide-A is distinguishable from the higher performance Glide P door operator by the number of motors. Glide A has one 135W motor, while the Glide P has two 135W motors. The Glide A door operator can move a total mass of 317 kg / 700 lb. at speeds up to 1.9 seconds with 42 in. center-opening doors. The Glide A door operator may still be considered for higher moving mass applications; however, with the expectation of lower speed and performance on a pre-contract basis. The Glide P can move a total mass of 420 kg / 925 lb. (or higher with reduced performance) and is the premium Otis door operator. In situations where a higher speed door opening profile is desired, or if heavy doors are in place, the Otis Glide P door operator is recommended and your local Otis office would have to be contacted for such work.

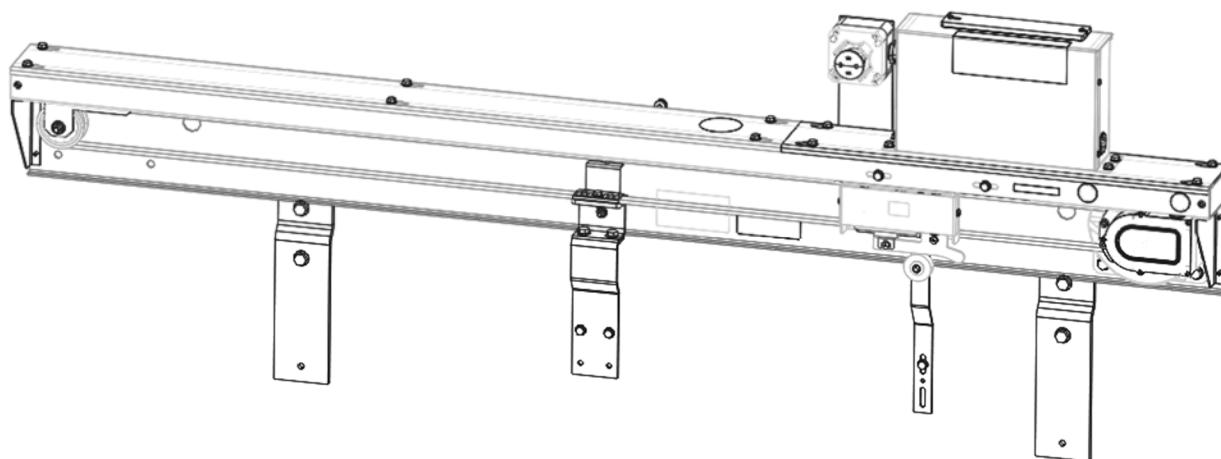



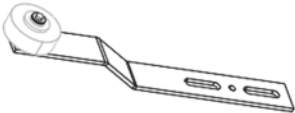

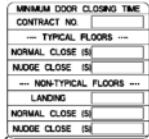
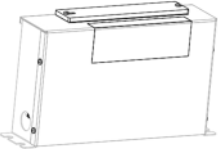

Figure 1: Glide A Door Operator

UNITEC OTIS GLIDE® A SPECIFICATION AND ORDERING GUIDE

2 Door Operator Components

The main components included with every Otis Glide A door operator are shown in Table 1. When any of the door operators are ordered, these components are supplied as required.

Table 1: Glide A Components

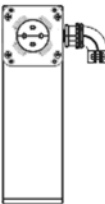
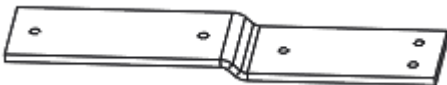
Description	Part Number	Image
Belt	KAA717AAL_	
Gate Switch Roller	AAA288AEK2 AAA288AEK4 288RH46	
Belt Clamp Components	AAA392DY1 AAA283BKY2 AAA386LQC1	
Door Closing Time Label	AAA102YT2	
Door Controller	KAA24360ABX1	
Door Hitch	AAA283BKX1 AAA283BKX3 AAA283BKX4	
Emergency Stop Switch	AAA25580BH1	
Mounting Bracket, Header, C/O, S/S & 2/S	AAA316JAN1 AAA316JAN2 AAA316JAN3 AAA316JAN4	

UNITEC OTIS GLIDE® A SPECIFICATION AND ORDERING GUIDE

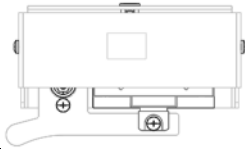
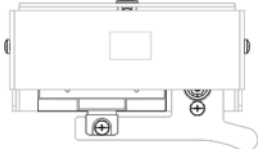
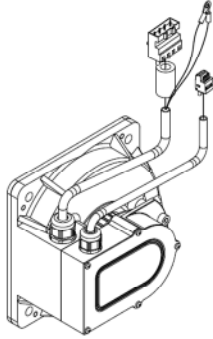
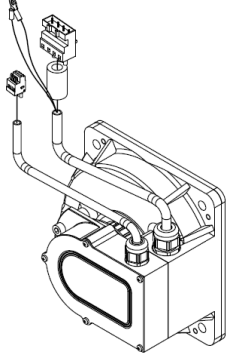
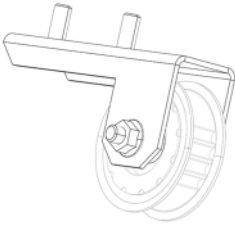
Description	Part Number	Image
Proximity Switch (DCP)	AAA608D12	
Gate Switch, RH	AAA25590AH1	
Gate Switch, LH	AAA25590AH2	
Motor Assembly, Left Hand, 135W	KAA24354AAX132	
Motor Assembly, Right Hand, 135W	KAA24354AAX32	
Assembly, Idler Pulley	AAA198BL1	

NOTE 1: When installing a Glide A door operator of any hand on a cab where header mounting bracket are not utilized (as seen in Figure 7 and Figure 8), purchase (1) bracket AAA283BKX5 (Figure 2) per operator. **This bracket is 24.4 in. long and provides extra length beyond what is available within the standard Glide A packaging.** This is not needed if the condition in the following NOTE 2 exists. Bracket sold separately, i.e. not included in any kit.

NOTE 2: When installing a Glide A door operator on a side-slide entrance (single-speed or two-speed) where 6940 interlocks are used and two-piece hangers are present, order (1) bracket AAA392EW1 (Figure 3) per operator. This bracket is 24.4 in. long and can be used to link the operator belt hitch to the door face and **provide clearance around the door vane.** Do not mount the gate switch roller bracket to the door hitch bracket. Bracket sold separately.

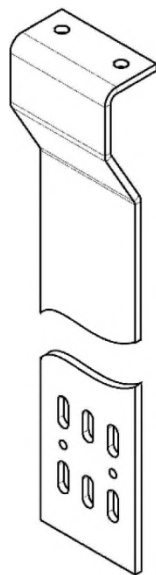

Figure 2: Door Interface Bracket for High Operator Mounting

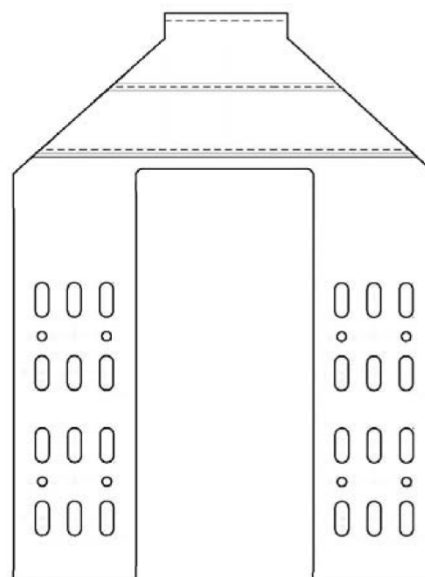

Figure 3: Door Interface Bracket for S/S and 2/S with Vane Interference

NOTE 3: Due to the Otis Glide A's acceleration capability, it is recommended to replace plastic or metal rollers with constant contacting urethane upthrust rollers. Constant contacting upthrust rollers reduce the tendency for the car doors to rock, while urethane increases the life expectancy of the roller and track. See Table 2 for urethane roller part numbers.

**Table 2: Glide A Compatible Otis Upthrust Rollers
(For help identifying hangers, see Appendix B for hanger illustrations.)**

Hanger Type	Glide A Compatible Upthrust Roller w/ Urethane Tire
Bent offset one piece applied or bent offset integral hanger with 7/8 in. wide 1/2-20 threaded nut for upthrust roller	AAA456ZQ2
Bent offset one piece applied or bent offset integral hanger with 3/4 in. wide M12 threaded nut for upthrust roller	AAA456ZQ8
OVL (One "L" shaped hanger bracket per door)	AAA456ZQ10
OSC Mod AAA24510D_* (Two "L" shaped hanger brackets per door)	AAA456ZQ14
AU (One "I" shaped hanger bracket per door used with 2-1/2 in. tall solid bar track)	AAA456ZQ16

NOTE: Urethane upthrust rollers cannot be used on the hoistway side doors due to UL fire certifications.

3 Door Hand & Type

3.1 Door Type

Refer to Figure 4 to determine the car door type. Single-speed side-slide, two-speed side-slide, and single-speed center-opening are supported by Otis Glide A.

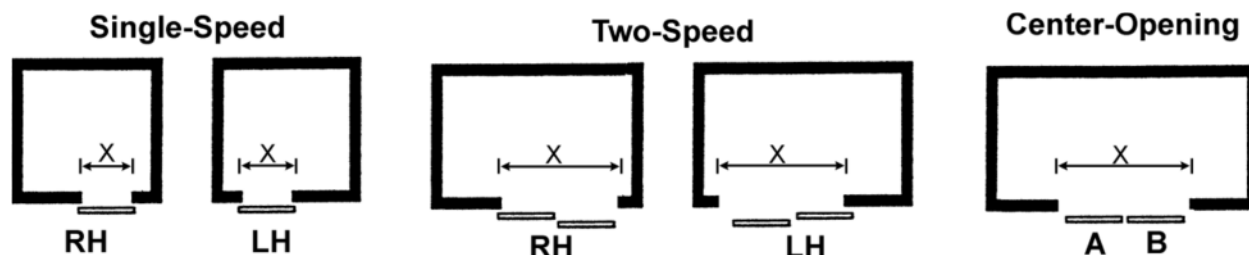

Figure 4: Supported Door Types

3.2 Door Hand

The “hand” (right-hand or left-hand) is determined *from inside the car*.

Single-Slide & Two-Speed Side Opening

- If the door opens to the left, the door is a left-hand door.
- If the door opens to the right, the door is a right-hand door.

Center-Opening

When both C/O doors are driven by the door operator, the hand is determined by which door contains the unlocking mechanism (vane or clutch). C/O doors that have hoistway door locks on both doors are considered dual-handed.

- The “hand” of a center-opening door operator is determined by which door (“A” or “B”) is being driven by the door operator. If the door operator drives door “A,” it is a right-hand door operator.

NOTE: Center-opening Glide A can be aircord or belt related. However, if replacing a New Equipment Glide A that utilizes an NG coupler (AAA24390N) or NG lock (AAA23400S), you must retain aircord relation.

4 Part Numbers, Availability, and Ordering Guidelines

Table 3 shows the part numbers of the Otis Glide A door operator arrangements. Mechanical space considerations are listed in Table 3a as well as Figures 5–8.

Table 3a: Otis Glide A Door Operator Assembly

Door Type	Door Hand	Entrance Width (in)		Part Number	Operator Length (in)
		Min	Max		
Side Slide: Single Speed & Two Speed	RH	48	60	AAA24450AE51	78.2
		41	47	AAA24450AE53	66.2
		39	40	AAA24450AE55	59.4
		24	38	AAA24450AE57	57.2
	LH	48	60	AAA24450AE59	78.2
		41	47	AAA24450AE61	66.2
		39	40	AAA24450AE63	59.4
		24	38	AAA24450AE65	57.2
Center Opening Aircord Related (Typical)	RH	51	60	AAA24450AE52	78.2
		37	50	AAA24450AE54	66.2
		33	36	AAA24450AE56	59.4
		23	32	AAA24450AE58	57.2
	LH	51	60	AAA24450AE60	78.2
		37	50	AAA24450AE62	66.2
		33	36	AAA24450AE64	59.4
		23	32	AAA24450AE66	57.2
Center Opening Belt Related*	RH	46	57	AAA24450AE52**	78.2
		39	45	AAA24450AE54**	66.2
		39	45	AAA24450AE56**	59.4
		27	36	AAA24450AE58**	57.2
	LH	46	57	AAA24450AE60**	78.2
		39	45	AAA24450AE62**	66.2
		39	45	AAA24450AE64**	59.4
		27	36	AAA24450AE66**	57.2

* Glide A cannot be belt related if using Otis NG, Otis OVL or GAL locks or clutch.

** You must select one of the below Belt Relating Kits.

Table 3b: Center-Opening Belt Relating Kit (Not Included with Operator)

Part Number	Description	Mounting Height†
AAA24430AS1	Belt Relating Kit, Standard Reach	7.5 in. or less
AAA24430AS2	Belt Relating Kit, Extended Reach	7.51–15 in.

† Mounting height is the distance from the bottom of the operator to the hanger rolling surface.

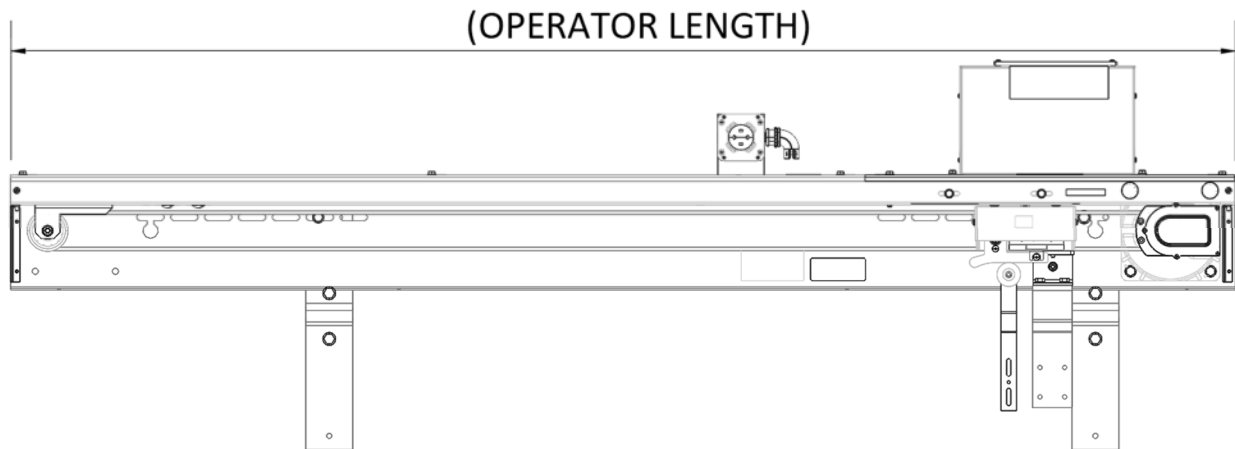

Figure 5: Otis Glide A – Operator Length

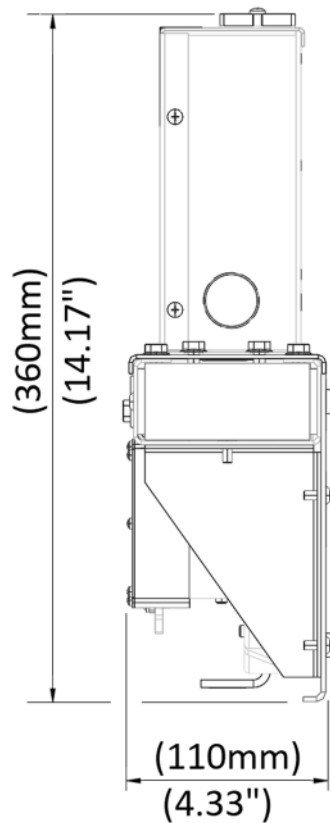

Figure 6: Otis Glide A Space Requirements—Door Operator Engine Unit

NOTE: When spacing out mounting locations, with concern for running clearance, the Glide A Door Operator is 110 mm (4.33 in.) thick. The conduit fitting behind the operator, which is designed to fit between the mounting brackets, is 25.4 mm (1 in.) beyond the back of the Glide A Door Operator. This must be considered when determining available space.

UNITEC OTIS GLIDE® A SPECIFICATION AND ORDERING GUIDE

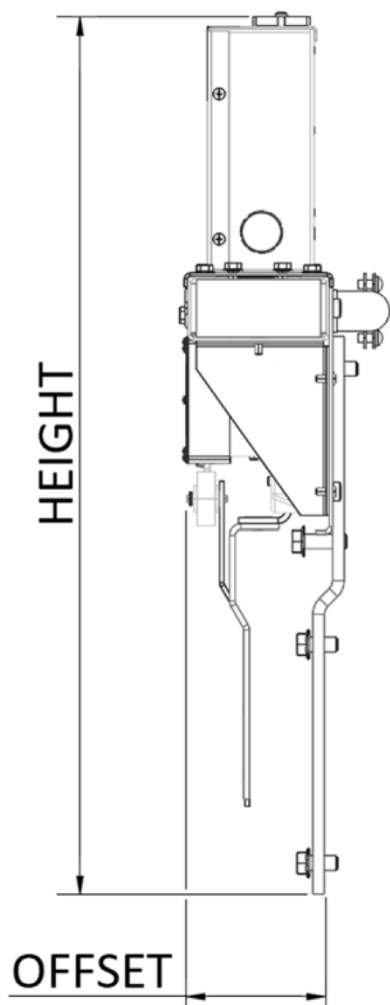

Figure 7: Otis Glide A Space Requirements for C/O & S/S with Header Mount Brackets (see Table 4)

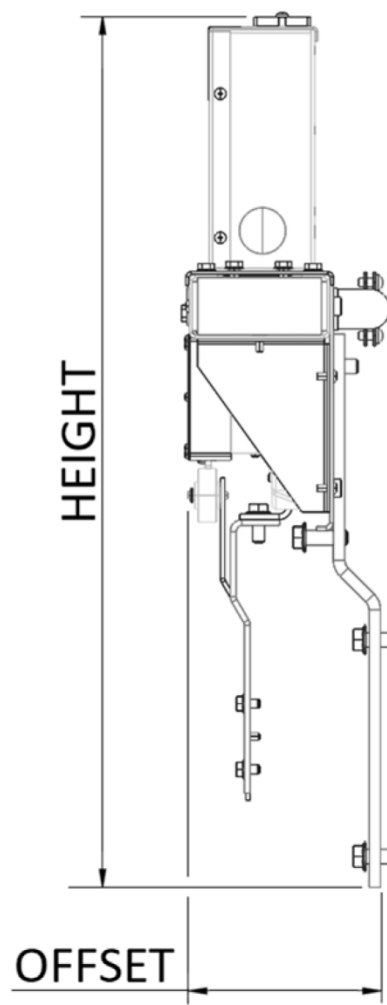

Figure 8: Otis Glide A Space Requirements for 2/S with Header Mount Brackets (see Table 4)

Table 4: Measurements for Otis Glide A on Installation to Existing Cab

Entrance Type	Height mm (in.)	Offset (mm)	Intended Application
C/O & S/S (Figure 7)	624 mm (24.5 in.)	92.5 mm (3.64 in.)	Mod & Open Order
		96.5 mm (3.79 in.)	New Equipment
2/S (Figure 8)		136 mm (5.35 in.)	New Equipment
		141 mm (5.55 in.)	Mod & Open Order

NOTE: When header mounted brackets cannot be used, see UT-ID 22.17.1-2 Mechanical Installation Guide, section 3 for alternative options.

5 Electrical Interface Components

5.1 Basic Information

The electrical interface components include the following items:

- **Power Supply:** The 0.5kVA power supply provides the required 220 VAC @ 2.1 A to power the Otis Glide A door operator and 120 VAC @ 2.1 A for the electrical interface pc board (where used). Various arrangements of the power supply are available depending on the building (primary) voltage. (See Table 7.)
- **Electrical Interface PC Board:** The discrete electrical interface pc board is typically needed for vintage relay-based systems that have 115VDC/VAC for door signals. The discrete electrical interface pc board is NOT needed when DO, DC, NDG inputs are 24 VDC and DOL, DCL, GSM outputs are connected to 24 VDC relays in the car controller (e.g. Otis Glide A replacing an i-Motion II or AT400 discrete door operator). The discrete electrical interface board provides:
 - Proper interface between high voltage (115 VAC) discrete elevator controller signals (DO, DC, NDG etc.) and the low voltage (24 VDC) Otis GLIDE® A input signals. The electrical interface board converts the elevator signal logic appropriately to provide the needed signal conditions for the Otis GLIDE® A door operator to perform the door motion functions.
 - Proper relay configuration to translate low current outputs (24 VDC, 20 mA) from the Otis GLIDE® A door operator (DOL, DCL, GSM, etc.) to high current relay contacts (1 NO, 1 NC contacts) for use in high voltage circuits in the car controller.
 - 115 VAC and AC return taps to allow for reduced travelling cable usage.



When the electrical interface pc board is NOT used, field must ensure that the inputs and outputs to the Otis Glide A door operator are within the specified limits.

The electrical interface assembly is not needed for systems with multidrop communication between the car controller and the door operator.

- **Multidrop Buffer Board Assembly (MDBB):** For certain controller systems, the multidrop buffer board is needed when there are **three or more** nodes in the multidrop network. For more information see section 5.2.4.

NOTE: The multidrop buffer board (MDBB) must be connected to the car controller using field wiring.

- **Constant Door Open and Door Close Signal Relays:** For discrete applications (typically on hydraulic elevators), the Glide A door operator requires a constant door open and door close command at the fully open and fully closed positions respectively to keep a constant torque on the motors. This function prevents the doors from sagging at these limit positions. If your car controller system disengages door open or door close at the fully open and fully closed positions, then additional circuitry needs to be added to the car controller system to meet this requirement. These additional relays and related components are provided in Table 10. **These parts MUST be ordered in separately from the discrete electrical interface kit.**

Most Otis discrete controllers meet this signal requirement except for the LRV and LRS controllers. For the LRV and LRS controllers the electrical interface kit with additional constant door open and door close relays is required. For more information on installing the Glide-A on LRV/LRS controllers, see UT-ID 22.17.1-8.

- **Harnesses:** The kits contain appropriate harnesses for interfacing:
 - The electrical interface pc board to the Otis Glide A door operator.
 - The discrete car controller signals from the COP or top of car junction box to the Otis Glide A door operator.
 - The multidrop link on the Otis Glide A door operator to the multidrop travelling cable.

5.2 Part Ordering Information



When installing the Glide A door operator on Otis LRS or LRV hydraulic systems, use UT-ID 22.17.1-8 for part ordering and specification.

Ordering the proper parts for the jobsite consists of the following steps:

1. Identifying car controller software compatibility.
2. Identifying traveling cable needs.
3. Selecting the power supply.
4. Selecting the electrical interface kit.
5. Selecting the ERU (for hydraulic applications only, if applicable).

5.2.1 Identifying Car Controller Software Compatibility

- A. If you have a hydraulic elevator, to ensure proper function of the constant DO and DC signal, please check that your car meets the minimum requirements listed in Table 5a.

Table 5a: Car Controller/Software Compatibility

Car Controller Type	Wiring Diagram	Motion Software	Hardware Dependency
LRS	No minimum requirement.	AAA30014AAK, or higher	Board revision E8121BC1 or higher
LRV			Board revision D8121DB1 or higher
LVM, 211	No minimum dependency.		

- B. For traction elevators, to ensure proper communication between the car controller and the Glide A, software on the car controller must comply with the requirements listed in Table 5b. For controller types not listed in the table below, contact Unitec Parts at 800-328-7840.



Review Table 5a & 5b to identify if Otis Elevator needs to be contacted to help update the car controller software. Depending on the current state of the system, additional software upgrades to MCSS, system wiring and hardware changes may be needed *before* the Glide A installation can be completed.

Table 5b: Car Controller/Software Compatibility

Car Controller Type	Controller Wiring Diagram	Motion Board Part Number	Motion Software
GEM/Mod GEM	A_A21290T, AEA21290CC or later	JFA26801AAF or higher	AAA300085AAJ or later
E311MV, E411MV	ABA21250AD or later	JGA26801AAF or higher	AAA300085AAJ or later
E411M-MS/VF	ABA21255X or later	ABA26800XH or higher, ABA26800AJV or higher	AAA30396AAE or later
E411M-HS	ACA21250A or later	ABA26800ABA or higher	AAA30045AAK or later
E411MC	AAA21255AG or later	ACA26800ANX or higher	AP131236AAA or later
E335M	CAA21255A	ACA26800MK or higher	AAA30145AAE or later
GEN2 (NGGC)	AAA21310AB or later	ABA26800AJV or higher	AAA30396BAA or later
GCS or GCS-M	AAA21310AE, AAA21310AM or later, AAA21305BW, AAA21305DE or later	ADA26800ANY or higher ADA26800AML, AAA26800AVP or higher proc bd	all versions are fine

Remember, LVM's, 211's and relay hydro's are all discrete so they don't show in this table.
HydroFit is hydro with serial CAN comms, but it will already have a Glide A so you won't be on this spreadsheet. :-)

5.2.2 Identifying Traveling Cables

The number of traveling cables required is listed Table . This table serves only as a guide and exact traveling cables required should be determined after reviewing the existing job wiring diagrams. (Job wiring diagrams should always be on hand when performing this work.)

It is assumed that a good PE (earth ground) connection point is available on the top of the car and that this PE is at the same potential as the PE in the car controller cabinet / machine room. **If this PE is not present, an additional 14 AWG PE travelling cable is required.**

NOTE: Wire gauges listed here are minimum required, thicker gauge travelling cables are acceptable.

Table 6: Traveling Cable Requirements for Otis Glide A

Configuration	Number of Traveling Cables Required		
	Gauge	Quantity ¹	Usage
NSAA Discrete	14 AWG	2	1 each for 240 VAC and AC RETURN
	18 AWG	8	1 each for 120 VAC, DO, DC, NDG, DOL, DCL, GS, /GS
NSAA Multidrop	14 AWG	2	1 each for 240 VAC and AC RETURN
	18 AWG	9 regular & 2 twisted pairs (total of 13)	1 each for /FSO, EDP ³ , CDBP ² , DOL ² , DOB ³ , 30 VDC, 30 VRTN, 2 for Gate Switch (GS), and 2 twisted pairs for RX+, RX-, TX+, TX

¹ It is assumed that a known PE point is available on the top of the car. If this is not available, an additional 14 AWG PE travelling cable will be required.

² The usage of these signals will depend on the car controller type. For precise information, refer to jobsite wiring diagrams before identifying travelling cable needs.

³ For E411-MC only.

5.2.3 Selecting the Power Supply

Identify the building/available primary voltage source and select the power supply using Table 7.

Table 7: Otis Glide A Power Supply

Otis P/N	Primary Voltage	Secondary Voltage (Glide A needs this to run)
AAA24430AE1	208–240 VAC	240 VAC @ 2.1A and 120 VAC @ 2.1A
AAA24430AE2	340–416 VAC	
AAA24430AE3	440–600 VAC	

5.2.4 Selecting the Electrical Interface Kit

To select the appropriate electrical interface kit, identify whether the application uses NSAA multidrop (typically traction controllers) or NSAA discrete interface (typically hydraulic controllers) for the existing door control system.

- If the application is NSAA multidrop, identify if the car controller system uses the (L)MCSS board. The (L)MCSS board, xxx26801AAF002, was used on the following control systems:
E411MV, E311MV, GEM, E311MV, MVS, HVS.
- If the application is NSAA Discrete, identify if the I/O on the existing door operator are 24VDC (e.g., i-motion II or AT400 discrete door operators) or 110VAC/VDC (legacy door operators).
- If the application is NSAA Discrete, also identify if the system provides a constant door open and door close command to the door operator. Most Otis elevator systems provide a constant door open/close command. However, systems including the LRV and LRS do NOT provide this constant command. For more information on this requirement, see section 5.1.

Use Table 8 to select the appropriate electrical kit (1 kit needed per door operator).

Table 8: Otis Glide A Electrical Interface Kit Descriptions

Application	Otis P/N	Typical Usage
Discrete	24-30VDC I/O w/constant Door Open/Door Close Signals	(1) AAA24430AP8 *
	110VAC I/O	(1) AAA24430AP4 *
	110VDC I/O	(1) AAA24430AP4 * (3) AAA613CZ12
	LRS or LRV system w/24-30VDC I/O (is the wiring diagram __7900__?)	(1) AAA24430AP8 * (3) AAA613CZ8 (3) AAA613CZ9 (3) AAA612T7 (1) 401B14 (3) AAA618AF25-KIT

UNITEC OTIS GLIDE® A SPECIFICATION AND ORDERING GUIDE

Serial (Multidrop or CAN)	Car Controller has motion board 26801AAF (i.e. GEM, 311)	(1) AAA24430AP16 ** & (1) AAA447AP235 (1) AAA447AP416 (1) AAA232GJ33 (1) AAA612AX6 (1) AAA303EP199 *** (1) GAA613HK2 ***	CLDO, Black Belt, i-motion or AT400 on traction systems GEM, MVS, HVS, E311, E411, MMS, MVF. Includes multidrop buffer board (but may not include the P6, P10 plug nor the resistor & Zener for the MBB).
	Car motion board= __26800AJV__ __26800XH__ __26800ABA__ __26800ANX__ __26800MK__ __26800ANY I/O Bd __26800AML Proc __26800AVP Proc	(1) AAA24430AP12 ** (1) AAA303EP199 *** (1) GAA613HK2 *** (1) AAA447AP416 ****	6970CL, Black Belt, i-motion or AT400 on traction systems with MLB3 or GECB based motion.
*Does controller provide constant DO & DC to the operator? It needs to! For LRV and LRS (which do NOT) see UT-ID 22.17.1-8			
** Only if "Table 5b" (shown above) has its minimum requirements met.			
*** If the car door detector possibly does not have a Normally Open circuit to feed EDP, you need this relay (and its cover) to convert the circuit. (Note: EDP does <u>not</u> input to a discrete Glide A door operator.)			
**** P10 plug added for load weighing communication just in case job site conditions require it.			

UNITEC OTIS GLIDE® A SPECIFICATION AND ORDERING GUIDE

Table 9 contains a list of sundries that are provided with the AAA24430AP kits to assist with installation of the electrical interface components.

Table 9: Field Sundries List (for reference only; items included in AAA24430AP kits)

Otis P/N	Description	Quantity per Kit			
		AAA24430AP4	AAA24430AP8	AAA24430AP12	AAA24430AP16
AAA646D2	Jumper Shunts with Handle	2			
440G1	Conduit Fitting, ½ in. (12.7 mm) for Flex Conduit	6		4	
342AP88	Flexible Conduit, 6 ft., ½ in. (1.83 M, 12.7 mm)	3		2	
334AY2	Bushing, Anti-Short	6		4	
AAA174AHY7	Ground Wire with 0.25 in. (6.4 mm) Ring Terminal, 6 ft. (1.83 m)	3		2	
---	Wire, Hook Up, UL Listed/Recognized, CSA Certified, 14 AWG, 105C, 600 VRMS, Black, 8 ft. (2.4 M)	3		2	
	Tapping Screw, Hex Washer Head 5.5 x 22	3		2	
	M4x35 Hex Head Bolt	6		---	
	M6x30 Hex Head Bolt			4	
	M4 Nut, Serrated Flange	6		---	
	M6 Nut, Serrated Flange			4	
	Washer, External Tooth, M5	3		2	
	Washer, External Tooth, M4	6		---	

For systems that do not provide a constant door open and door close command to the door operator (e.g. LRV/LRS) order the items listed in Table 10 in addition to ordering one of the AAA24430AP4 or AAA24430AP8 kits.



When installing the Glide A door operator on Otis LRS or LRV hydraulic systems, use UT-ID 22.17.1-8 for part ordering and specification.

Table 10: Additional Components List for System without Constant Door Open and Door Close Signals

Otis PN	Description	Quantity (per door operator)
AAA613CZ8	Relay, 24VDC Coil, 4NO 4NC	3
AAA612T7	Diode, 1000V, 1A, 1N4007 (for relay coil suppression)	3
401B14	DIN rail, 13.5 in. long	1
618AE2	Relay sockets	3

5.2.5 Selecting the ERU

If the Glide A door operator is installed on a hydraulic elevator system, the Emergency Return Unit (ERU) may have to be changed. If the current ERU provides 110VDC output, it **must** be replaced with an ERU that provides 220VDC. The typical Otis ERU AUT-O-SAFE® ACA7900BH1 that provides 110VDC, must be replaced with the 220VDC version, ACA7900BH2.



ERUs are not included in the electrical interface kit and **MUST** be ordered separately.

ERU Application	Otis P/N	UT-ID
<p>If you currently have an Otis ERU that provides 110VDC to the door operator, then you NEED to change it to this 220VDC version.</p> <p style="text-align: center;">OR</p> <p>If you currently do not have and need to install a new ERU, order these parts.</p>	<p>(1) ACA7900BH2 (1) AAA718E15-2PACK (1) ABA21602J5-UNITEC (1) AAA447BE42</p>	<p>UT-ID 1_1_14_0-6 Emergency Rescue Unit (ERU)</p>

Appendix A: Part Numbers

The following table lists all part numbers this document mentions.

Table 11: Related Part Numbers

Description	Part Number
Connector, 10-Pin	AAA447X41
Contact, 120 VAC Coil, 3 NO + 1 NC, 250 VAC 10A Contacts	AAA613DL30
Din Rail, 35 mm, 13.5 in.	401B14
Electrical Interface Kit for Multidrop for Systems w/ (L)MCSS	AAA24430AP16
Electrical Interface Kit for Multidrop for Systems w/o (L)MCSS	AAA24430AP12
Electrical Interface Kit for NSAA Discrete Applications for 24VDC I/O	AAA24430AP8
Electrical Interface Kit for NSAA Discrete Applications for 110VAC I/O	AAA24430AP4
Enclosure for AAA24430AE Power Supply	AAA308UD2
Fuse, Slo-Blo, 3 A, 600 V	AAA375BK26
Fuse, Slo-Blo, 3.5 A, 600 V	AAA375BK28
Harness, Otis Glide A Multidrop	AAA24431H21
Harness, Otis Glide A Discrete	AAA24431H22
Junction Box, Top-Of-Car	AAA25580AM1
Multidrop Buffer Board Assembly with Plastic Holder	AAA21380AE1
Multidrop Buffer Board PCBA	AAA26800MJ1
Otis Glide A Door Operator for Mod – See Table 3 for specifications	AAA24450AE51
Otis Glide A Door Operator for Mod – See Table 3 for specifications	AAA24450AE52
Otis Glide A Door Operator for Mod – See Table 3 for specifications	AAA24450AE53
Otis Glide A Door Operator for Mod – See Table 3 for specifications	AAA24450AE54
Otis Glide A Door Operator for Mod – See Table 3 for specifications	AAA24450AE55
Otis Glide A Door Operator for Mod – See Table 3 for specifications	AAA24450AE56
Otis Glide A Door Operator for Mod – See Table 3 for specifications	AAA24450AE57
Otis Glide A Door Operator for Mod – See Table 3 for specifications	AAA24450AE58
Otis Glide A Door Operator for Mod – See Table 3 for specifications	AAA24450AE59
Otis Glide A Door Operator for Mod – See Table 3 for specifications	AAA24450AE60
Otis Glide A Door Operator for Mod – See Table 3 for specifications	AAA24450AE61
Otis Glide A Door Operator for Mod – See Table 3 for specifications	AAA24450AE62
Otis Glide A Door Operator for Mod – See Table 3 for specifications	AAA24450AE63
Otis Glide A Door Operator for Mod – See Table 3 for specifications	AAA24450AE64
Otis Glide A Door Operator for Mod – See Table 3 for specifications	AAA24450AE65

UNITEC OTIS GLIDE® A SPECIFICATION AND ORDERING GUIDE

Table 11: Related Part Numbers (continued)

Description	Part Number
Otis Glide A Door Operator for Mod – See Table 3 for specifications	AAA24450AE66
Center-Opening Belt Relating Kit – Standard Reach	AAA24430AS1
Center-Opening Belt Relating Kit – Extended Reach	AAA24430AS2
Power Supply, 208–240 VAC Primary Voltage	AAA24430AE1
Power Supply, 340–416 VAC Primary Voltage	AAA24430AE2
Power Supply, 440–600 VAC Primary Voltage	AAA24430AE3
RC Relay Coil Suppressor	AAA613DL61
Traveling Cable, 14 AWG, 4 Conductors	REP-J 4-14
Belt	KAA717AAL_
Gate Switch Roller	AAA288AEK2 AAA288AEK4 288RH46
Belt Clamp Components	AAA392DY1 AAA283BKY2 AAA386LQC1
Door Closing Time Label	AAA102YT2
Door Controller	KAA24360ABX1
Door Hitch	AAA283BKX1
Door Hitch	AAA283BKX3
Door Hitch	AAA283BKX4
Door Hitch	AAA283BKX5
Bracket, Door Hitch	AAA392EW1
Emergency Stop Switch	AAA25580BH1
Mounting Bracket, Header, 2/S	AAA316JAN1
Mounting Bracket, Header, C/O & S/S	AAA316JAN2
Mounting Bracket, Header, C/O & S/S	AAA316JAN3
Mounting Bracket, Header, 2/S	AAA316JAN4
Proximity Switch (DCP)	AAA608D12
Gate Switch, RH	AAA25590AH1
Gate Switch, LH	AAA25590AH2
Motor Assembly, Left Hand, 135W	KAA24354AAX132
Motor Assembly, Right Hand, 135W	KAA24354AAX32
Assembly, Idler Pulley	AAA198BL1